

ATTENZIONE - ATTENTION - ACHTUNG

- VERIFICARE LE MISURE DI INGOMBRO PER POSSIBILE INTERFERENZA SU ALCUNI MODELLI DI MACCHINE
- Please check the overall sizes for possible interferences on some machine models
- Bitte überprüfen sie das ausmass um mögliche interferenzen auf einigen maschinen modellen zu vermeiden

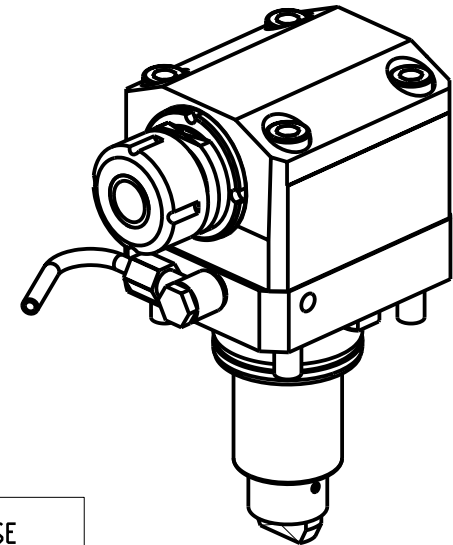
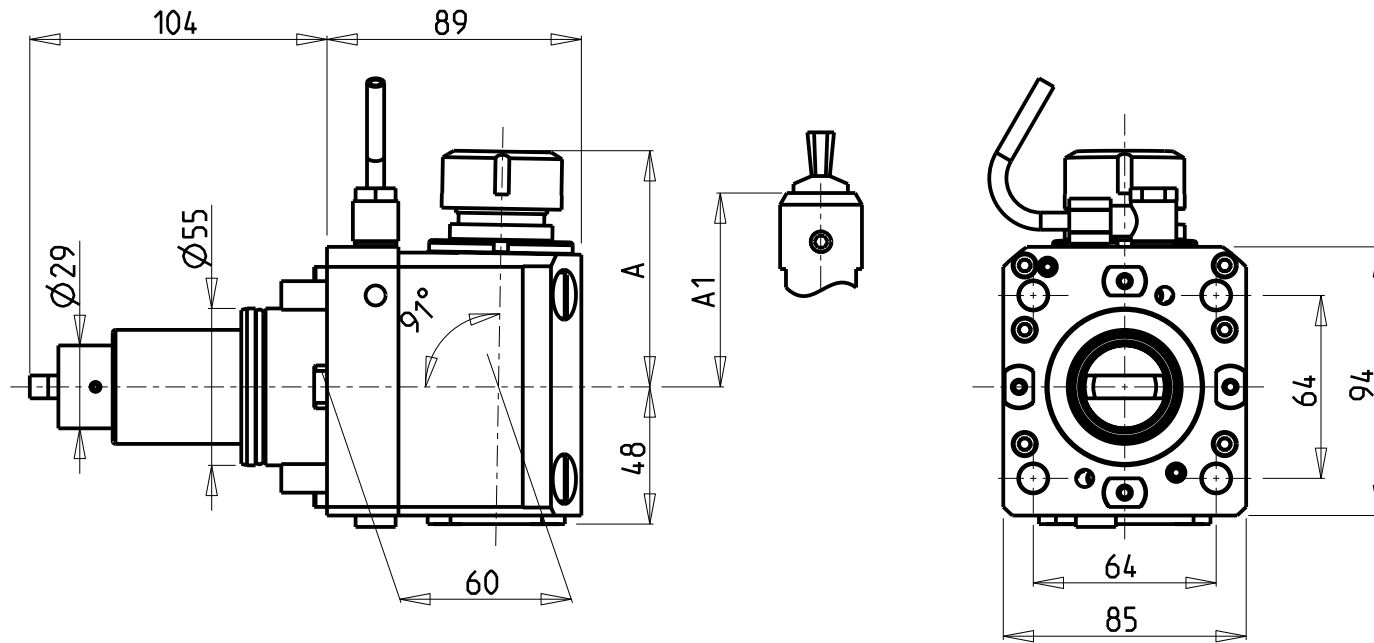

Cod. MT	Mandrino Spindle Spindel	I	RPM	Coppia Max Max Torque Max Drehmoment	Reversibile lato mandrino/contromandrino Reversible sub/main spindle side Umkehrbare Spindel-seite/ Gegenspindel-seite	Lubrificazione est. Ext. coolant Ausseukuehlung	A	A1	CHIAVI NON INCLUSE Keys not included Schluessel nicht einbegriffen	
0319125	ER25	1:1	6000	50Nm	X	X	82.35	-	CHSTER25	CHUB36 o 0100000
0319108	WELDON 8	1:1	6000	50Nm	X	X	-	76.5	-	-
0319110	WELDON 10	1:1	6000	50Nm	X	X	-	76.5	-	-
0319112	WELDON 12	1:1	6000	50Nm	X	X	-	76.5	-	-
0319116	WELDON 16	1:1	6000	50Nm	X	X	-	73.5	-	-

DOOSAN BMT 55

MOD: PUMA 230-240M/MS-280LM - PUMA 1500-2000-2500M/MS/Y/SY - LINX 300 M - PUMA 2100 12ST. - PUMA 2600 16ST.
PUMA TL2000-2500 (M) - PUMA GT2100-2600 M

MODULO MOTORIZZATO ASSIALE PER POLIGONATURA INTERNA H=60mm

Axial driven tool for internal polygon-making H=60mm

Axial angetriebenes Werkzeug fuer interne Facettierung H=60mm

Subject to change without notice.

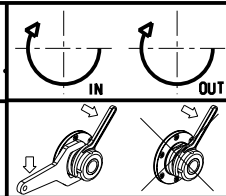

M.T. srl

Via Casino Albini 480
Tel. 0541/956034-957884
Fax 0541/956341
47842 S. GIOVANNI IN M. (RN)
e-mail: mtma@mtmarchetti.com
http://www.mtmarchetti.com

PRODUZIONE MODULI ROTANTI



PAGINA DW 0230-2-10